



Operator's Instructions

## Oil flow divider

---

**LFD 20**  
**LFD 30**

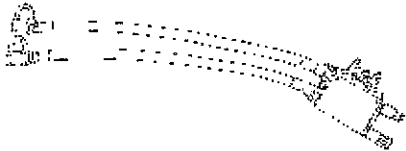

AIB  
2005-06

© Copyright 2005  
ATLAS COPCO CONSTRUCTION TOOLS AB  
NACKA • SWEDEN  
[www.atlascopco.com](http://www.atlascopco.com)

No 3392 5004 01

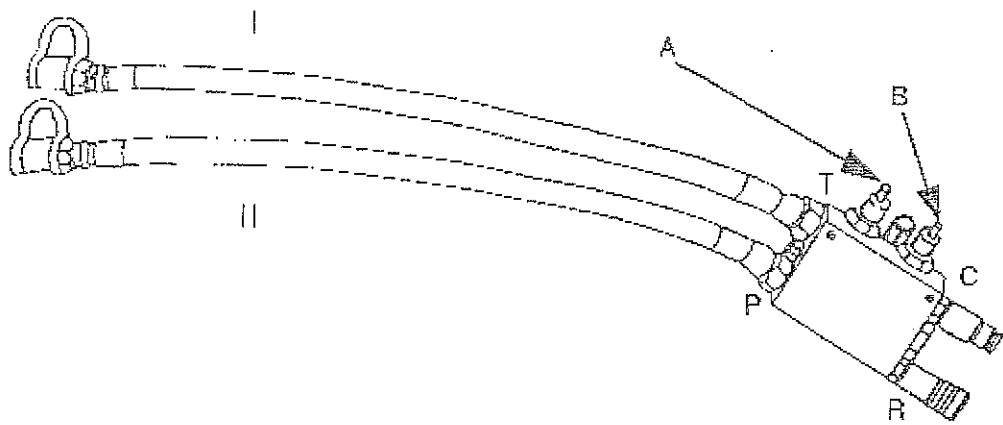

Fig. 1

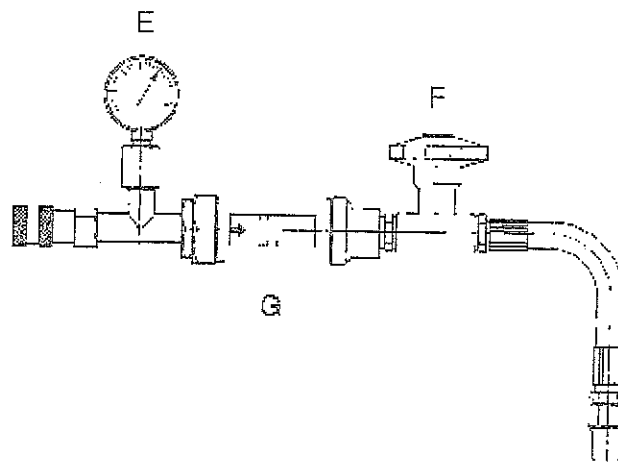

Fig. 2

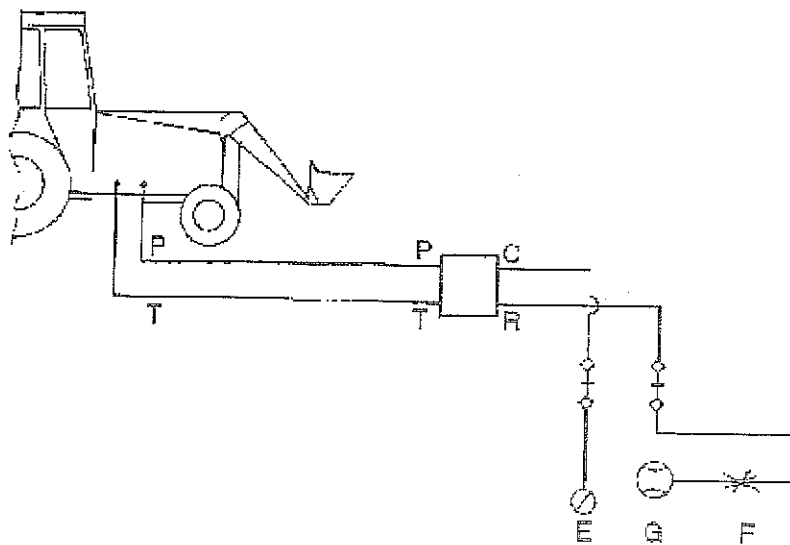

Fig. 3

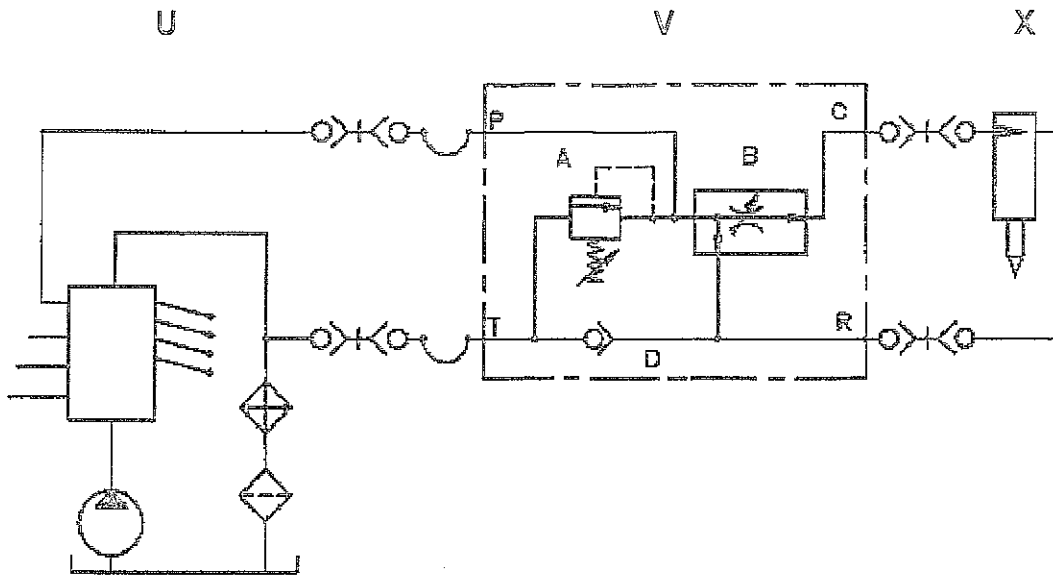

Fig. 4

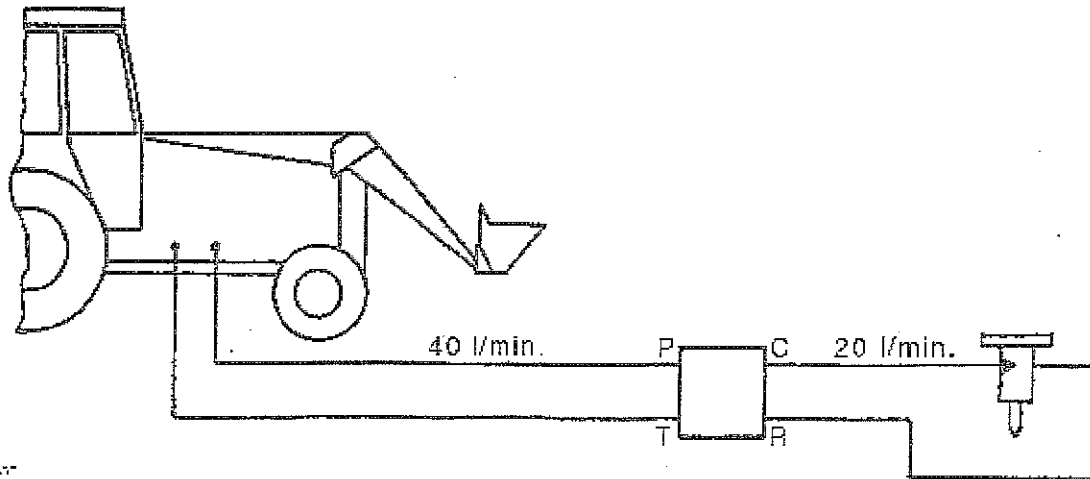

Fig. 5

## Safety regulations

These instructions contain important sections dealing with safety. Special attention must be paid to all framed safety text that begins with a warning symbol (triangle) followed by a signal word, as shown below



denotes a hazard or hazardous procedure which CAN lead to serious or life-threatening injuries if the warning is not observed.



denotes a risk or risky procedure which CAN lead to personal injury or damage to equipment if the caution is not observed.

### Also observe the following general safety rules:

- Before using the product, read through **these instructions** carefully.
- For reasons of product safety, the product must not be modified.
- Use approved personal protective equipment.
- Use Atlas Copco Genuine Parts only.
- Replace damaged or worn plates.
- Only trained personnel may work on the product.

<b>Illustration page page 2-3</b>	
Oil flow divider	Fig. 1
Test equipment	Fig. 2
Arrangement for setting up oil flow dividers	Fig. 3
Hydraulic system diagram	Fig. 4
Example of an application	Fig. 5
<b>Designation</b>	
I = Tank coupling	G = Flow meter
II = Pump coupling	P = Pressure
A = Pressure limiting valve	R = Return
B = Flow regulator	T = Tank port
C = Regulated flow	U = Power source
D = Check valve	V = Oil flow divider
E = Pressure gauge	X = Hydraulic tool
F = Throttle valve	



**Use of the oil flow divider for any purpose other than that stated in the instructions for use may subject the oil flow divider to stresses for which it was not designed. This may result in the risk of injury or of damage to the hydraulic system.**

1. Read the entire instruction manual thoroughly before using the oil flow divider.
2. Carefully read the instruction manual for the hydraulic tool that will be connected to the oil flow divider.
3. Make sure that the oil flow divider is correctly set up to work with the hydraulic tool to be used with it.
4. If you are in any doubt when installing or connecting the oil flow divider or connecting it to the power source, contact a representative for advice.

## Introduction

The purpose of these instructions is to communicate the information about operation and servicing that is necessary for safe and efficient use of the oil flow divider.

It is important to note the following points before using the oil flow divider.

**Description**

The oil flow divider must be used when the oil flow delivered by the power source is greater than the flow required by the hydraulic tool. The oil flow divider ensures a constant oil flow which, depending on the model, can be adjusted between 20 and 25 or between 25 and 38 liters/minute. Excess oil is returned to the tank on the power source via the tank port (T).

The following functions are integrated with the oil flow divider: An adjustable pressure limiting valve (A) which is used to set the maximum permitted working pressure. There is an adjustable flow regulator (B) to set the oil flow to the hydraulic tool. There is also a check valve (D) to prevent damage to the hydraulic tool if the pressure line is accidentally connected to the tank port (T).

The excess oil, which is returned to the tank on the power source, creates heat in the hydraulic system. This heat must be dissipated by the oil cooler of the power source. To avoid unnecessary heat being generated in the hydraulic system the speed and/or output of the pump in the power source should be adjusted so that the oil flow rate is not excessive.

**Setting the pressure and the flow**

We recommend using the special test equipment or a similar pressure and flow meter to set the oil pressure and flow.

1. Connect the test equipment to the oil flow divider as shown in Fig. 3.
2. Fully open the throttle valve (F) on the test equipment by turning it anticlockwise.
3. Fully open the flow regulator (B) of the oil flow divider by turning it anticlockwise.
4. Start the power source.
5. Gradually close the throttle valve (F) on the test equipment until the pressure gauge (E) reads about 100 bar. If you cannot reach 100 bar by closing the throttle valve (F), adjust the pressure limiting valve (A) by turning it clockwise until the correct pressure is reached. Allow the oil to warm up to working temperature.
6. Fully close the throttle valve (F) by turning it slowly clockwise. While the throttle valve is being closed, check that the pressure does not rise above 160 bar. If it is, open the pressure limiting valve (A).
7. When the throttle valve (F) is completely closed, adjust the pressure to 150 bar with the pressure limiting valve (A).
8. Check the setting by opening the throttle valve (F) and then closing it. The flow meter (G) must not indicate a drop in the flow before a pressure of 130 bar is reached.

9. Adjust the throttle valve (F) until the pressure gauge (E) reads 100 bar. Adjust the flow with the flow regulator (B) on the oil flow divider to the flow stated in the table below for the relevant oil flow divider. The flow reading is taken from the flowmeter (G).

**Checking the oil flow divider**

If set up correctly, the oil flow divider will retain its performance for a long time. Even so, the oil flow rate and the setting of the relief valve should be checked annually.

The pressure and flow settings of the oil flow divider are set in the same way as described above, except that the oil flow divider setting should only be altered if necessary.

1. Connect the test equipment to the oil flow divider as shown in Fig. 3.
2. Fully open the throttle valve (F) on the test equipment by turning it anticlockwise.
3. Start the power source.
4. Gradually close the throttle valve (F) on the test equipment until the pressure gauge (E) reads about 100 bar. Allow the oil to warm up to working temperature.
5. Fully close the throttle valve (F) by turning it slowly clockwise.
6. When the throttle valve (F) is completely closed, the pressure reading on the pressure gauge (E) should be 150 bar. If necessary, adjust the pressure with the pressure limiting valve (A).
7. Adjust the throttle valve (F) until the pressure gauge (E) reads 100 bar. Take the flow reading from the flowmeter (G). The flow reading should be as stated in the table below for the relevant oil flow divider. If necessary, adjust the pressure with the flow regulator (B).

**Values for setting up oil flow dividers****Model LFD 20**

Oil flow rate	20 l/min (5.3 US g.p.m.)
Oil pressure	15 MPa (150 bar) (2175 psi)

**Model LFD 30**

Oil flow rate	30 l/min (8 US g.p.m.)
Oil pressure	15 MPa (150 bar) (2175 psi)

## Technical data - Oil flow dividers

There are two sizes of oil flow divider.

### Model LFD 20

Max. oil flow rate in	60 l/min (15.8 US g.p.m.)
Regulated oil flow rate	20-25 l/min (5.3-6.6 US g.p.m.)
Pressure limiting valve, adjustable	0-21 MPa (0-210 bar) (0-3045 psi)
Pump connection	0.4 m ½" hydraulic hose with quick-release coupling (female)
Tank connection	0.4 m ½" hydraulic hose with quick-release coupling (male)
Tool connection, pressure	½" quick-release coupling (male)
Tool connection, tank	½" quick-release coupling (female)

### Model LFD 30

Max. oil flow rate in	120 l/min (31 US g.p.m.)
Regulated oil flow rate	25-30 l/min (6.6-8 US g.p.m.)
Pressure limiting valve, adjustable	0-21 MPa (0-210 bar) (0-3045 psi)
Pump connection	0.4 m ¾" hydraulic hose with quick-release coupling (female)
Tank connection	0.4 m ¾" hydraulic hose with quick-release coupling (male)
Tool connection, pressure	½" quick-release coupling (male)
Tool connection, tank	½" quick-release coupling (female)

Any unauthorized use or copying of the contents or any part thereof is prohibited. This applies in particular to trademarks, model denominations, part numbers and drawings.