

LP 18-40 E PAC/LP 18-30 E PAC

Power Pack

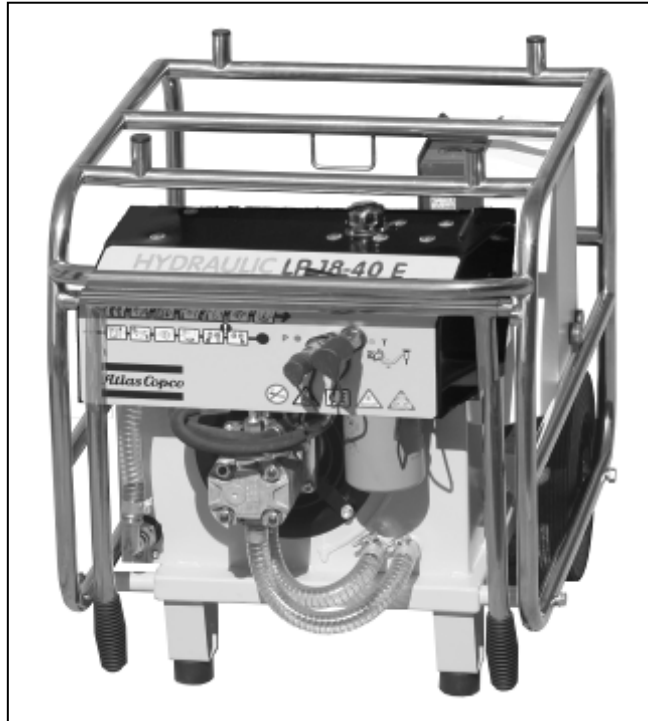

LP 18-40 E PAC, LP 18-30 E PAC

Safety and Operating Instructions

Atlas Copco

ATLAS COPCO CONSTRUCTION TOOLS AB
NACKA • SWEDEN
www.atlascopco.com

2006-10
No 3392 5027 01 a

CONTENTS

INTRODUCTION	2
SAFETY INSTRUCTIONS	2
Introduction to safety	2
Safety symbols used	2
General safety rules	3
Protective equipment.....	3
MARKINGS	4
Identification	4
CE	4
Safety signs on the Power Pack	4
GENERAL INFORMATION.....	4
Parts identification	5
OPERATING INSTRUCTIONS	6
Preparation before starting	6
Starting the motor	6
Stopping the motor	6
Hydraulic control and connectors.....	6
Connecting/disconnecting hoses	7
How to check the hydraulic system	7
Service schedules	8
Scrapping and waste disposal	9
TROUBLE SHOOTING	9
TECHNICAL DATA.....	10
Noise declaration statement	11

INTRODUCTION

These operating and safety instructions must be read before operating the machine. Instructions for operation and basic maintenance are included. The purpose of this booklet is to give the machine user an understanding of how to safely and efficiently use and maintain the machine.

SAFETY INSTRUCTIONS

Introduction to safety

SAFETY INSTRUCTIONS	
<ul style="list-style-type: none">• Before starting, read all instructions carefully	
<ul style="list-style-type: none">• Special attention must be paid to information alongside this symbol	
<ul style="list-style-type: none">• Only use Atlas Copco genuine parts	

To reduce the risk of serious injury to yourself or others, read these safety instructions before using the Power Pack. Post these safety instructions at work locations, provide copies to employees, and make sure that everyone reads the safety instructions before using the Power Pack. Comply with all safety regulations.

These instructions have been compiled from international safety standards and form part of the operating instructions. Signs and decals that are important for your safety and the care of the Power Pack are included with each power pack. Make sure that they are legible. New decals can be ordered using the spare parts list.

Safety symbols used

The indications DANGER, WARNING and CAUTION, as used in the safety instructions, have the following meanings:



DANGER

Immediate hazard which WILL result in serious or fatal injury if the warning is not observed



WARNING

Hazard or hazardous procedure which COULD result in serious or fatal injury if the warning is not observed



CAUTION

Hazard or hazardous procedure which COULD result in injury or damaged equipment if the warning is not observed

General safety rules

- The Power Pack and accessories must only be used for their purpose
- Learn how the Power Pack is switched off in the event of an emergency
- Only qualified and trained persons may operate or maintain the Power Pack
- Keep the Power Pack in a safe place out of the reach of children, locked up
- Pay attention and look at what you are doing
- Use your common sense
- Do not use the Power Pack when you are tired or under influence of drugs, alcohol or anything else that may influence your vision, reaction or judgement
- Never leave the Power Pack turned on
- Avoid lifting a higher weight than that allowed according to your local environmental working regulations
- Regular maintenance is prerequisite for machine safety. Carefully follow the operating instructions. Replace damaged and worn components in good time. For major service to the Power Pack, contact your nearest authorized workshop. When cleaning mechanical parts with solvent, make sure to comply with current health and safety regulations and ensure sufficient ventilation
- Explosions and fire can be caused by sparks from the exhaust or the electrical system. Do not use the machine in closed areas with flammable material, vapour or dust.

Protective equipment

Always use approved personal protective equipment. Operators and other staff in the proximity areas where work is in progress must as a minimum use the following approved protective equipment:

- Hearing protection

When the Power Pack is used as a power source for breakers, cut-off saws and similar tools, use the following personal protective equipment:

- Protective helmet
- Safety glass with side protection
- Respiratory protection when appropriate
- Protective gloves
- Protective boots

MARKINGS

Identification

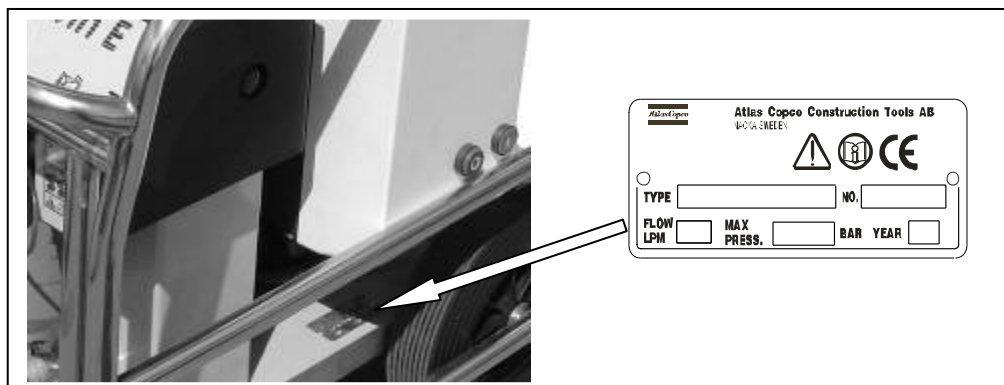

CE

The CE marking verifies that the machine is CE approved. The marking is on the ID-tag. See the “Declaration of Conformity” supplied with the Power Pack for more information.

Safety signs on the Power Pack

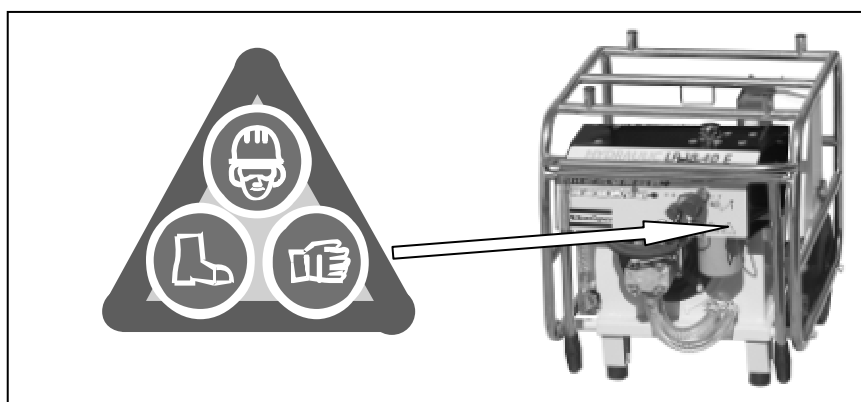

GENERAL INFORMATION

The Atlas Copco LP 18-40 E PAC and LP 18-30 E PAC are hydraulic power packs designed for operating Atlas Copco hydraulic breakers and other tools.

The Power Pack is fitted with an 11 kW electric motor. The flow for the LP 18-40 E PAC is 40 l.p.m., and for the LP 18-30 E PAC the flow is 30 l.p.m.

Parts identification

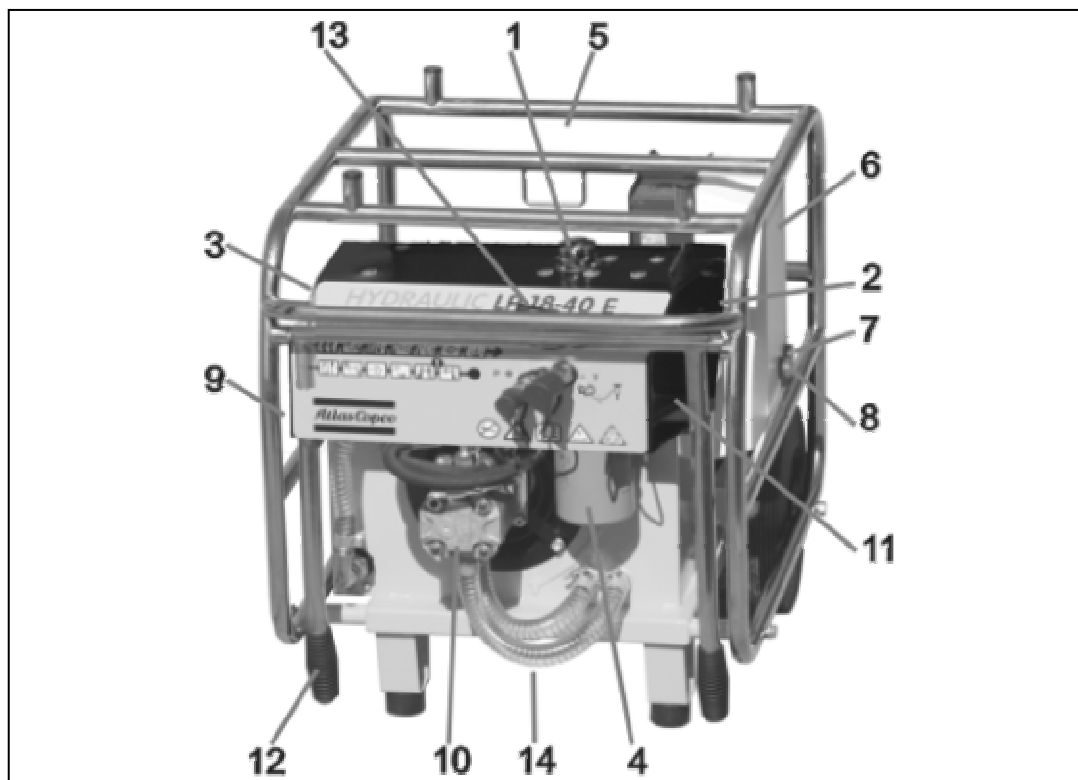

- | | | | |
|---|----------------------------------|----|-----------------------|
| 1 | Filler cap, hydraulic oil | 8 | Stopping button |
| 2 | Sight glass, hydraulic oil level | 9 | Oil cooler |
| 3 | Filter condition gauge | 10 | Hydraulic pump |
| 4 | Hydraulic oil filter | 11 | Pressure relief valve |
| 5 | Electric motor | 12 | Foldable handles |
| 6 | Electro box | 13 | By-pass valve |
| 7 | Starting button | 14 | Drain plug |

OPERATING INSTRUCTIONS

Preparation before starting

The following checks should be made each time you return to the Power Pack after leaving it for a period of time. All these checks concern the serviceability of the Power Pack. Some concern your safety.

- Remove dirt and debris especially from around the linkage and hydraulic oil cooler
- Clean all safety decals. Replace any that are missing or cannot be read
- Inspect the Power Pack and hoses generally for signs of damaged and missing parts
- Check for fluid and fuel leakages beneath the Power Pack
- Check the security of the hinged frame
- Check the hydraulic oil level and add as necessary
- Position the Power Pack in a safe position
- Ensure that the hydraulic couplings are clean and fully serviceable
- Ensure that any hydraulic tool you plan to use is compatible with the model of the Power Pack you are using. See the section **Flow rates**

Starting the motor

1. Connect the power supply
2. Turn the hydraulic by-pass valve (C) to the OFF position
3. Start the motor by pressing the green button and check the direction of the rotation by looking into the fan at the rear end of the motor. The motor has to rotate clockwise (seen from the rear end of the motor)
4. If the motor rotates in the wrong direction, stop the motor immediately. Disconnect the electric socket and switch the phase (see illustration). Restart the motor



CAUTION

Letting the motor rotate in the wrong direction for a long time could harm the pump.

Stopping the motor

1. Turn the hydraulic by-pass valve to the OFF position
2. Stop the motor by pressing the red button

Hydraulic control and connectors

The by-pass valve (F) shall be in the OFF position when starting and in the ON position when using the tool.

Connectors (G) and (H) are used to connect the Power Pack to the tool as follows:

- Connector (G) Return (female)
- Connector (H) Feed (male)

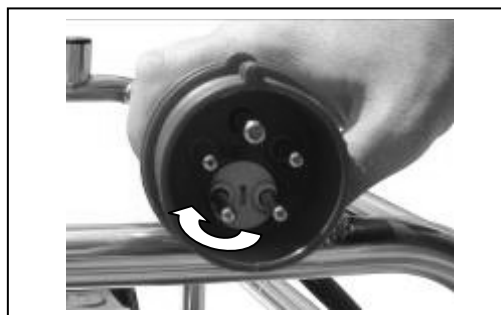



Connecting/disconnecting hoses

 **CAUTION**

Ensure that any tool you plan to use is compatible with the model of the Power Pack you are using.

Non-compatible tools might harm both the Power Pack and the tools.

Check the section Flow rates in this instruction book and compare the flow rate with the technical specifications in the instruction book for the tool.

Disconnecting hoses

1. Prepare the Power Pack
 - a) Turn the by-pass valve to the OFF position
 - b) Stop the motor
2. Remove the hoses
 - a) Rotate the collar on the female coupling
 - b) Release the return line
 - c) Release the feed line

Note: The couplings are unlocked by moving the collar back on the coupling

 **WARNING**

Do not disconnect the hoses when the Power Pack is running or if the hydraulic oil is hot.

Hot hydraulic oil might cause serious burns.

Connecting hoses

1. Prepare the Power Pack
 - a) Turn the by-pass valve to the OFF position
 - b) Stop the motor
2. Inspect the couplings
 - a) Ensure that the couplings are clean and serviceable
3. Connect the hoses
 - a) Attach the return line
 - b) Attach the feed line
 - c) Rotate the collar on the female coupling to secure the coupling
4. Check the hydraulic oil level
 - a) Start the motor and run the Power Pack to fill up the hydraulic circuit
 - b) Check the hydraulic oil level

How to check the hydraulic system

To set or check the oil flow and the pressure relief valve we recommend using the Atlas Copco test equipment or similar test equipment.

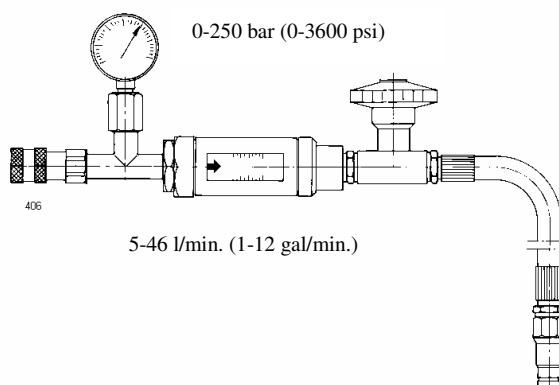

Part number 3371 8011 54

How to check

1. Stop the motor (see the section **Stopping the motor**)
2. Connect the test equipment to the Power Pack. Male (B) to the return connector and female (A) to the feed connector on the Power Pack. Make sure that the loading valve of the test equipment is fully open
3. Start the motor (see the section **Starting the motor**)
4. Move the by-pass valve on the Power Pack to the ON position
5. Turn the loading valve, until the gauge shows approx. 70 bar (1000 psi) and allow the Power Pack to warm up for 3-4 minutes
6. Slowly close the loading valve until the pressure gauge shows the nominal pressure according to the technical specifications
7. Check that the flow is according to the flow rate in the technical specifications

Note: The inaccuracy of the reading on the flow meter is ± 2 l.p.m. (± 0.5 gal/min). If the performance is not in accordance with the technical specifications for the Power Pack, please see the section **TROUBLE SHOOTING**

Service schedules

A poorly maintained Power Pack is a hazard. Doing regular maintenance and lubrication jobs as listed in these schedules will help keep the Power Pack in a safe working condition.

Apart from the daily jobs, the schedules are based on the operation hours of the Power Pack. Keep a regular check of hours in use. Do not use a Power Pack that is due for regular service. Rectify any defects found during regular maintenance before clearing the Power Pack for use.



WARNING

Maintenance must be done only by suitably qualified and competent persons.

Before doing any maintenance, make sure that the Power Pack is safe and correctly sited on level ground.

Daily

1. Clean the Power Pack in general
2. Check fittings for cracks or leaks. Replace if necessary
3. Check for damages
4. Check hydraulic fluid level
5. Check motor oil level
6. Check hydraulic couplings
7. Check hydraulic hoses
8. Check hydraulic oil filter

IMPORTANT

When the filter gauge needle remains in the red sector (while the motor is running idle and the oil is service warm), the filter must be replaced. The old filter is removed by turning it clockwise (use a filter strap wrench if necessary). Tilting the Power Pack rearwards will minimise oil spilling.

Before mounting the new filter, it is recommended to grease the surface of the seal with oil in order to ease correct tightening of the filter.



WARNING

Fine jets of hydraulic oil at high pressure can penetrate the skin. Do not use your fingers to check for hydraulic oil leaks. Do not put your face close to suspected leaks. Hold a piece of cardboard close to suspected leaks and then inspect the cardboard for signs of hydraulic oil. If hydraulic oil penetrates your skin, get medical help quickly.

Note: Check tightness of nuts, bolts, screws and hose fittings after the first days of operation and thereafter in accordance with the maintenance schedule

Every 3 months

1. Do the daily jobs
2. Check tightness of nuts, bolts, screws and hose fittings

Every 300 hours or every year

1. Do the daily jobs and jobs every 3 months
2. Change the hydraulic oil
3. Change the hydraulic oil filter

Scrapping and waste disposal

Used and worn out parts must be treated and disposed of in such a way that the greatest possible part of them can be recycled and the influence on the environment kept as low as possible

TROUBLE SHOOTING



WARNING

Maintenance must be done only by suitably qualified and competent persons.

Problem	Cause	Solution
Motor does not start	Insufficient power supply	Check power supply
	Thermal relay disconnected	Activate relay
Low hydraulic oil level	Damaged hoses	Check and replace if necessary
	Leaking connections	Check for tightness/leaks
	Defect hose couplings	Replace couplings
Poor tool performance	Low pressure relief valve setting	Adjust valve
	High back pressure	Check hose system for blockage
	Worn hydraulic pump	Replace pump
Frothy or creamy coloured hydraulic oil	Air or water in oil	Check for loose connections on line to pump
		Make sure that the filler cap on the tank is not loose
		Check that oil level is at the top of the sight glass

Problem	Cause	Solution
Tool runs hot	Poor siting of Power Pack causing warm air to recirculate	Resite Power Pack for free air circulation
	Blocked oil cooler	Blow cooler clean. NEVER use a wire brush
	Defect fan	Replace fan
	Back pressure too high	Check hose system
	Tool defect	Check and service tool

TECHNICAL DATA

Dimensions

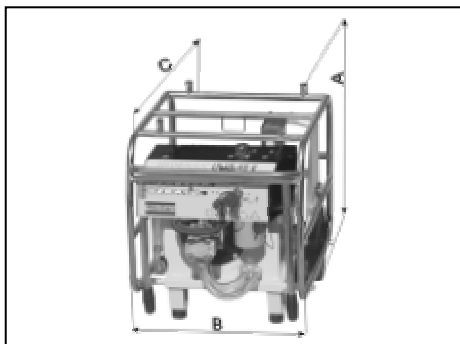

Height (A)	705 mm (27.8")
Width (B)	600 mm (23.6")
Length (C)	745 mm (29.3")
Weight with oil	123 kg (271 lbs)

Motor type

Motor Three-phase induction A.C. motor, bipolar, 3 x 400 V

Performance 11 kW

Power supply 380-420 V, 50/60 Hz, 32 Amp

Hydraulic system

Circuit type Open centre

Pump type Gear pump, directly driven from the motor crankshaft by means of a flexible coupling

Filtration 25 μ filter in return line. Filter by-pass valve in valve block

Cooling system Thermostatically controlled air blast oil cooler

Fluids, lubricants, capacity and specification

Item	Capacity	Fluid/lubricant
	Litres (gal,US)	
Hydraulic fluid	7 (1.85)	Mobil EAL 224 or similar

Flow rates

The European Hydraulic Tool Manufacturers Association (E.H.T.M.A.) has categorised hydraulic power packs and tools in terms of flow rate and working pressure.

Our LP 18-40 E PAC and LP 18-30 E PAC are categorised by the E.H.T.M.A. as below:

Power Pack LP 18-40 E PAC

Flow rate, l.p.m. (gal,US)	38 (10)
Nominal pressure, bar (psi)	120 (1800)
Max. pressure, bar (psi)	150 (2200)
E.H.T.M.A. category	E

Power Pack LP 18-30 E PAC

Flow rate, l.p.m. (gal,US)	30 (8)
Nominal pressure, bar (psi)	150 (2200)
Max. pressure, bar (psi)	172 (2500)
E.H.T.M.A. category	D

Note: Atlas Copco hydraulic power packs are clearly marked with E.H.T.M.A. categories. It is important that any tool used with the Power Pack is of a compatible category. If any doubt, consult your Atlas Copco dealer.

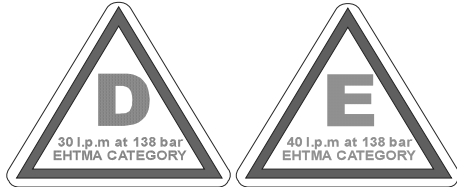

WARNING

The setting of the pressure relief valve on the Power Pack can in some cases be higher than the prescribed max. pressure according to the E.H.T.M.A. category.

A too high pressure relief valve setting can harm the tool.

Readjust the pressure relief valve on the Power Pack if the technical specifications of the tool prescribe a lower pressure relief valve setting than the standard setting of the Power Pack.

Noise declaration statement

Total emitted A-weighted sound power level (2000/14/EC):

Measured	$L_{WA\ m}$	97 dB re 1 pW
Declared	$L_{WA\ d}$	98 dB re 1 pW
Guaranteed	$L_{WA\ g}$	101 dB re 1 pW
K value	K.....	1.9 dB

Sound pressure level 1 m L_{PA}
(EN/ISO 11203) 86 dB

These declared values were obtained by laboratory type testing in compliance with the stated standards and are not adequate for use in risk assessment. Values measured in individual work places may be higher than the declared values. The actual exposed values and risk of harm experienced by an individual user are unique and depend upon the way the user works, the work place as well as the exposure time and the physical condition of the user.

IMPORTANT

We, Atlas Copco Construction Tools AB, cannot be held liable for the consequences of using the declared values, instead of values reflecting the actual exposure, in an individual risk assessment in a work place situation, over which we have no control.

Hose length

- 1 In normal ambient temperature, 0-40 °C (32-104 °F), the maximum hose length should not exceed 25 m (82 ft)
- 2 Normally, 7 m of Twin hoses are to be used for the Power Pack.

Twin hose and other accessories are shown in the spare parts list.