

# LP 13-20 DE PAC

---

## Power Pack



---

**LP 13-20 DE PAC**

## Safety and Operating Instructions

**Atlas Copco**

©Copyright 2005  
ATLAS COPCO CONSTRUCTION TOOLS AB  
NACKA • SWEDEN  
[www.atlascopco.com](http://www.atlascopco.com)

2005-12  
No 3392 5019 01 a

# CONTENTS

INTRODUCTION .....	2
SAFETY INSTRUCTIONS.....	2
Introduction to safety.....	2
Safety symbols used.....	2
General safety rules.....	3
Protective equipment.....	3
MARKINGS.....	4
Identification.....	4
CE.....	4
Safety signs on the Power Pack .....	4
GENERAL INFORMATION.....	4
Parts identification.....	5
OPERATING INSTRUCTIONS.....	6
Preparation before starting.....	6
Starting the engine (electric start).....	7
Starting the engine (recoil start) .....	7
Stopping the engine.....	7
Hydraulic control and connectors.....	8
Connecting/disconnecting hoses .....	8
How to check the hydraulic system.....	9
Service schedules.....	10
Scrapping and waste disposal.....	11
TROUBLE SHOOTING .....	11
TECHNICAL DATA .....	12
Noise declaration statement.....	13

## INTRODUCTION

These operating and safety instructions must be read before operating the machine. Instructions for operation and basic maintenance are included. The purpose of this booklet is to give the machine user an understanding of how to safely and efficiently use and maintain the machine.

## SAFETY INSTRUCTIONS

### Introduction to safety

SAFETY INSTRUCTIONS	
• Before starting, read all instructions carefully	
• Special attention must be paid to information alongside this symbol	
• Only use Atlas Copco genuine parts	

To reduce the risk of serious injury to yourself or others, read these safety instructions before using the Power Pack. Post these safety instructions at work locations, provide copies to employees, and make sure that everyone reads the safety instructions before using the Power Pack. Comply with all safety regulations.

These instructions have been compiled from international safety standards and form part of the operating instructions. Signs and decals that are important for your safety and the care of the Power Pack are included with each power pack. Make sure that they are legible. New decals can be ordered using the spare parts list.

### Safety symbols used

The indications DANGER, WARNING and CAUTION, as used in the safety instructions, have the following meanings:



#### DANGER

Immediate hazard which WILL result in serious or fatal injury if the warning is not observed



#### WARNING

Hazard or hazardous procedure which COULD result in serious or fatal injury if the warning is not observed



#### CAUTION

Hazard or hazardous procedure which COULD result in injury or damaged equipment if the warning is not observed

## General safety rules

- The Power Pack and accessories must only be used for their purpose
- Learn how the Power Pack is switched off in the event of an emergency
- Only qualified and trained persons may operate or maintain the Power Pack
- Keep the Power Pack in a safe place out of the reach of children, locked up
- Pay attention and look at what you are doing
- Use your common sense
- Do not use the Power Pack when you are tired or under influence of drugs, alcohol or anything else that may influence your vision, reaction or judgement
- Never leave the Power Pack turned on
- Avoid lifting a higher weight than that allowed according to your local environmental working regulations
- Regular maintenance is prerequisite for machine safety. Carefully follow the operating instructions. Replace damaged and worn components in good time. For major service to the Power Pack, contact your nearest authorized workshop. When cleaning mechanical parts with solvent, make sure to comply with current health and safety regulations and ensure sufficient ventilation
- Breathing the Power Pack's exhaust gases can harm and possibly kill you. Do not start or run the Power Pack in enclosed areas, even if the doors and windows are open. Start and run the Power Pack outdoors.

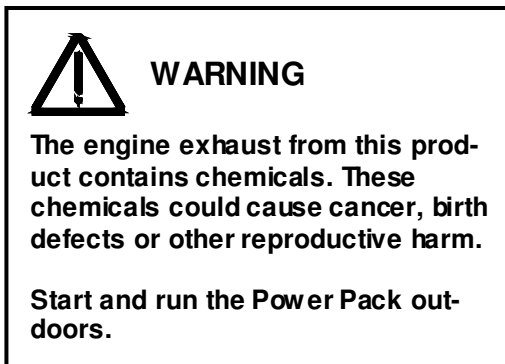

- Explosions and fire can be caused by sparks from the exhaust or the electrical system. Do not use the machine in closed areas with flammable material, vapour or dust.

## Protective equipment

Always use approved personal protective equipment. Operators and other staff in the proximity areas where work is in progress must as a minimum use the following approved protective equipment:

- Hearing protection

When the Power Pack is used as a power source for breakers, cut-off saws and similar tools, use the following personal protective equipment:

- Protective helmet
- Safety glass with side protection
- Respiratory protection when appropriate
- Protective gloves
- Protective boots

## MARKINGS

### Identification

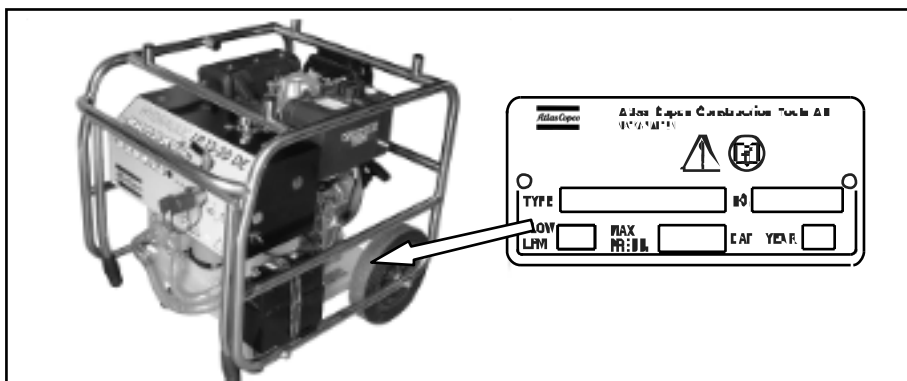

### CE

The Atlas Copco LP 13-20 DE PAC fulfils all safety regulations in the Directive 98/37/EC. The Atlas Copco LP 13-20 DE PAC does **not** comply with the regulations in the Directive 2000/14/EC with regard to noise. The Atlas Copco LP 13-20 DE PAC has therefore **no** CE marking. The Atlas Copco LP 13-20 DE PAC is therefore not approved for use on the EU market.

### Safety signs on the Power Pack

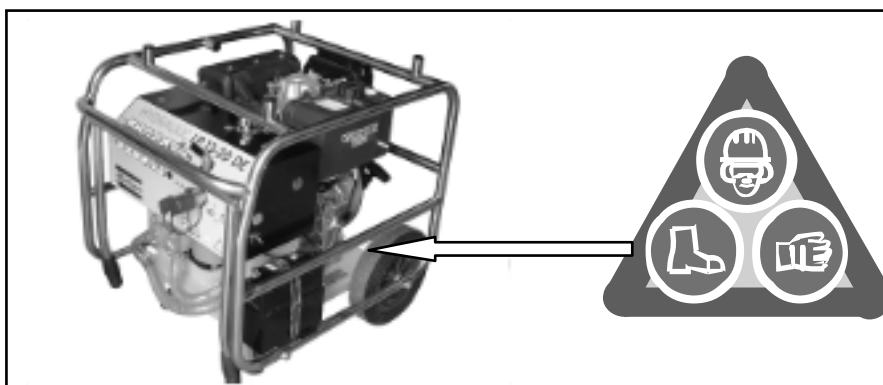

## GENERAL INFORMATION

The Atlas Copco LP 13-20 DE PAC is a hydraulic Power Pack designed for operating Atlas Copco hydraulic breakers and other tools.

The Power Pack is fitted with a 10 HP Yanmar, air cooled, 1 cylinder 4-stroke diesel engine with electric start. The flow of the LP 13-20 DE PAC is 20 l.p.m.

## Parts identification

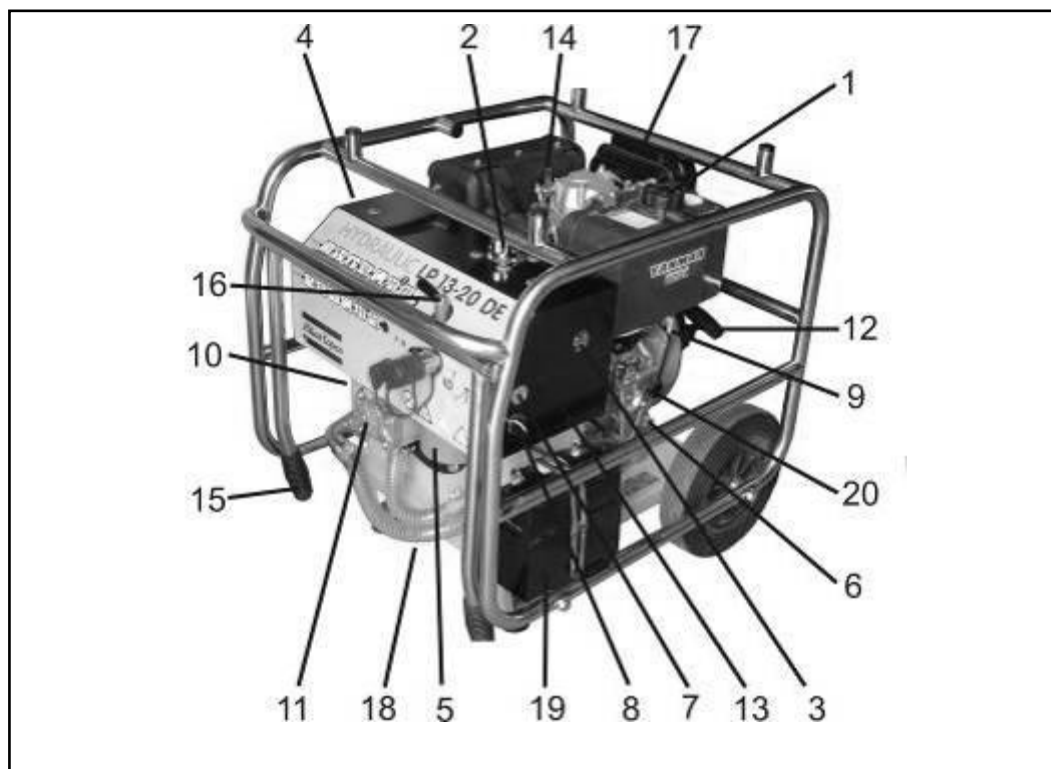

1	Filler cap, fuel	11	Hydraulic pump
2	Filler cap, hydraulic oil	12	Recoil start
3	Sight glass, hydraulic oil level	13	Pressure relief valve
4	Filter condition gauge	14	Decompression lever
5	Hydraulic oil filter	15	Foldable handles
6	Engine oil, dipstick	16	By-pass valve
7	Starting switch	17	Air filter
8	Ignition switch OFF and ON	18	Drain plug
9	Fuel tap	19	Battery
10	Oil cooler	20	Throttle lever

# OPERATING INSTRUCTIONS

## Preparation before starting

The following checks should be made each time you return to the Power Pack after leaving it for a period of time. All these checks concern the serviceability of the Power Pack. Some concern your safety.

- Remove dirt and debris especially from around the linkage and hydraulic oil cooler
- Clean all safety decals. Replace any that are missing or cannot be read
- Inspect the Power Pack and hoses generally for signs of damaged and missing parts
- Check for fluid and fuel leakages beneath the Power Pack
- Check the security of the hinged frame
- Make sure the fuel filler cap is tightly closed
- Check the hydraulic oil level and add as necessary
- Position the Power Pack in a safe position
- Ensure that the hydraulic couplings are clean and fully serviceable
- Ensure that any hydraulic tool you plan to use is compatible with the model of the Power Pack you are using. See the section **Flow rates**
- Check the engine oil level and add oil as necessary
- Ensure that you have adequate fuel for the job. Top up as necessary, taking care not to overfill



### WARNING

- **Diesel and its vapours are flammable and explosive. Fire or explosion can cause severe burns or death**
- **Keep naked flames away from the Power Pack**
- **Do not smoke while refuelling the Power Pack or working with the engine**
- **Do not refuel with the engine running. Turn off the engine and let the engine cool before refuelling**
- **Do not overfill the tank beyond the top of the red plug inside the fuel tank filter**

### **Starting the engine - electric start**

1. Set the hydraulic by-pass valve (A) in the OFF position
2. Set the fuel tap (B) in the O position (open)
3. Set the engine speed lever (C) in the START position
4. Turn the starting key (D) clockwise to the START position
5. Remove your hand from the key, as soon as the engine starts

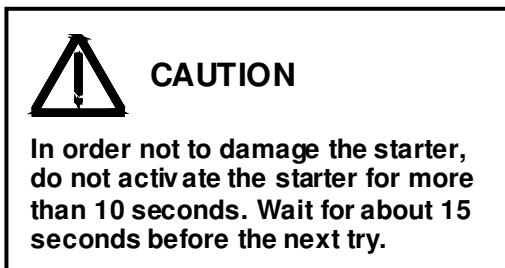

6. Let the engine warm up without load for about 3 minutes

### **Starting the engine - recoil start**

1. Set the hydraulic by-pass valve (A) in the OFF position
2. Set the fuel tap (B) in the O position (open)
3. Set the engine speed lever (C) in the START position
4. Pull out the recoil starting handle (E) to the point where you feel strong resistance and then return it to its initial position
5. Push down the decompression lever (F). It will return automatically when the recoil starter is pulled
6. Pull out the recoil starting handle (E) briskly with both hands

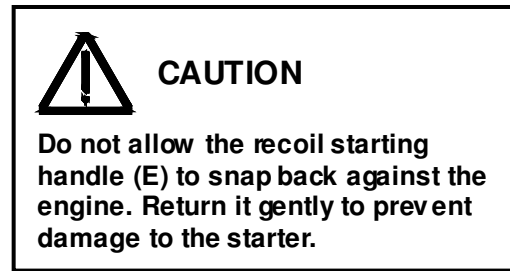

7. In cold weather, when your engine is hard to start, remove the rubber plug (G) of the rock arm cover and add 2 cc of engine oil before starting

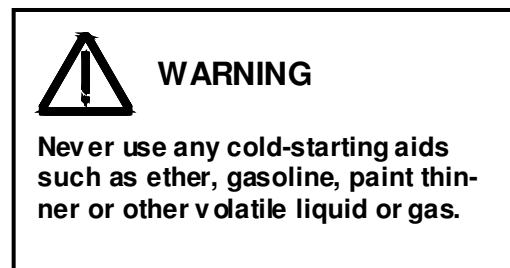

8. Let the engine warm up without load for about 3 minutes

### **Stopping the engine**

1. Turn the hydraulic by-pass valve (C) to the OFF position
2. Move the throttle lever (H) to the low speed position and let the engine run for about 3 minutes without load
3. Move the throttle lever (H) to the STOP position
4. Turn the ignition key (D) counter clockwise to the OFF position
5. Set the fuel tap lever (B) to the S position
6. Slowly pull out the recoil starting handle (E) until resistance is felt and leave the handle in this position. This prevents rust from forming while the engine is not in use

**WARNING**

If the engine keeps on running even after the speed lever is placed in the STOP position, stop the engine either by closing the fuel tap (S position) or by loosening the nut of the high-pressure fuel pipe at the pump side.

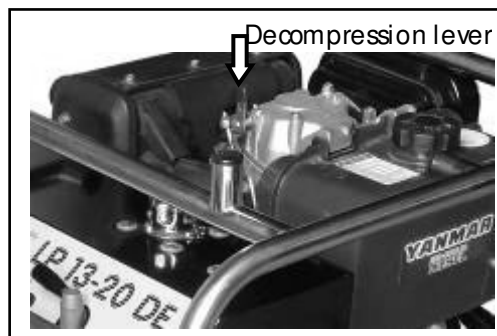
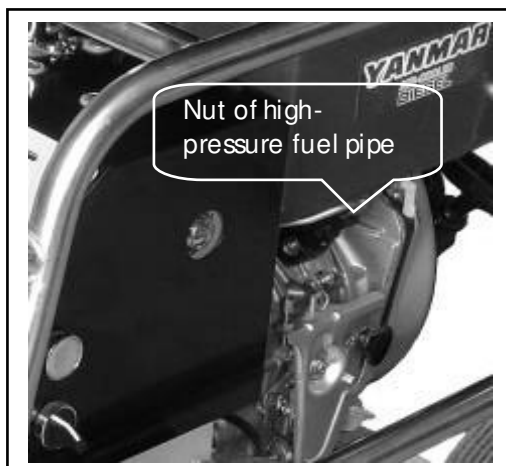
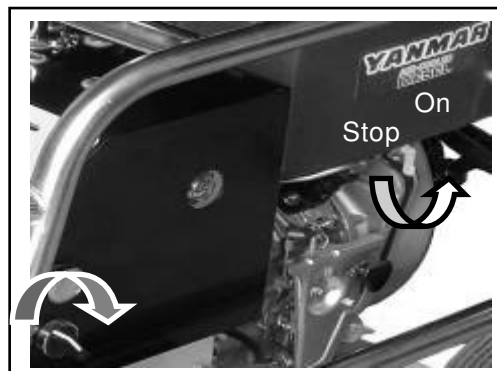

- Connector (G) Return (female)
- Connector (H) Feed (male)

**CAUTION**

When stopping the engine, reduce the load slowly. Do not stop the engine suddenly since it may cause the temperature to rise abnormally.

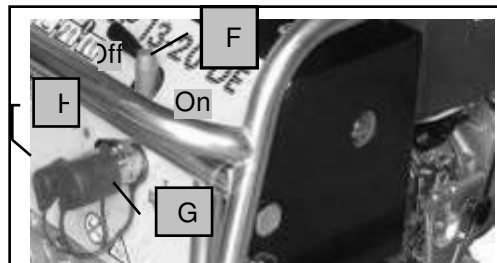
**CAUTION**

Do not stop the engine with the decompression lever.

**Connecting/disconnecting hoses****CAUTION**

Ensure that any tool you plan to use is compatible with the model of the Power Pack you are using.

Non-compatible tools might harm both the Power Pack and the tools.

Check the section Flow rates in this instruction book and compare the flow rate with the technical specifications in the instruction book for the tool.

**Hydraulic control and connectors**

The bypass valve (F) shall be in the OFF position when starting and in the ON position when using the tool.

Connectors (G) and (H) are used to connect the Power Pack to the tool as follows:

### Connecting hoses

1. Prepare the Power Pack
  - a) Turn the by-pass valve to the OFF position
  - b) Stop the engine
2. Inspect the couplings
  - a) Ensure that the couplings are clean and serviceable
3. Connect the hoses
  - a) Attach the return line
  - b) Attach the feed line
  - c) Rotate the collar on the female coupling to secure the coupling
4. Check the hydraulic oil level
  - a) Start the engine and run the Power Pack to fill up the hydraulic circuit
  - b) Check the hydraulic oil level

### Disconnecting hoses

1. Prepare the Power Pack
  - a) Turn the by-pass valve to the OFF position
  - b) Stop the engine
2. Remove the hoses
  - a) Rotate the collar on the female coupling
  - b) Release the return line
  - c) Release the feed line

**Note:** The couplings are unlocked by moving the collar back on the coupling



**WARNING**

**Do not disconnect the hoses when the Power Pack is running or if the hydraulic oil is hot.**

**Hot hydraulic oil might cause serious burns.**

### How to check the hydraulic system

To set or check the oil flow and the pressure relief valve we recommend using the Atlas Copco test equipment or similar test equipment.

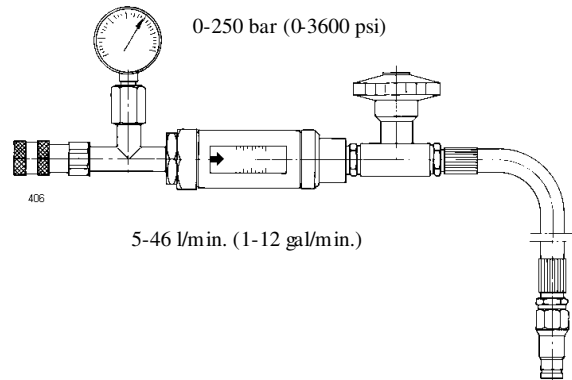

Part number 3371 8011 54

### How to check

1. Stop the engine (see the section **Stopping the engine**)
2. Connect the test equipment to the Power Pack. Male (B) to the return connection and female (A) to the feed connection on the Power Pack. Make sure that the loading valve of the test equipment is fully open
3. Start the engine (see the section **Starting the engine – electric start**)
4. Move the by-pass valve on the Power Pack to the ON position
5. Turn the loading valve, until the gauge shows approx. 70 bar (1000 psi) and allow the Power Pack to warm up for 3-4 minutes
6. Slowly close the loading valve until the pressure gauge shows the nominal pressure according to the technical specifications

7. Check that the flow is according to the flow rate in the technical specifications

**Note:** The inaccuracy of the reading on the flow meter is  $\pm 2$  l.p.m. ( $\pm 0.5$  gal/min). If the performance is not in accordance with the technical specifications for the Power Pack, please see the section **TROUBLE SHOOTING**

## Service schedules

A poorly maintained Power Pack is a hazard. Doing regular maintenance and lubrication jobs as listed in these schedules will help keep the Power Pack in a safe working condition.

Apart from the daily jobs, the schedules are based on the operation hours of the Power Pack. Keep a regular check of hours in use. Do not use a Power Pack that is due for regular service. Rectify any defects found during regular maintenance before clearing the Power Pack for use.



### WARNING

**Maintenance must be done only by suitably qualified and competent persons.**

**Before doing any maintenance, make sure that the Power Pack is safe and correctly sited on level ground.**

### Daily

1. Clean the Power Pack in general
2. Check fuel lines, tank, fuel cap and fittings for cracks or leaks. Replace if necessary
3. Check for damages
4. Check hydraulic fluid level
5. Check engine oil level
6. Check hydraulic couplings
7. Check hydraulic hoses
8. Check hydraulic oil filter

### IMPORTANT

**When the filter gauge needle remains in the red sector (while the engine is running idle and the oil is service warm), the filter must be replaced. The old filter is removed by turning it clockwise (use a filter strap wrench if necessary). Tilting the Power Pack rearwards will minimise oil spilling.**

**Before mounting the new filter, it is recommended to grease the surface of the seal with oil in order to ease correct tightening of the filter.**



### WARNING

**Fine jets of hydraulic oil at high pressure can penetrate the skin. Do not use your fingers to check for hydraulic oil leaks. Do not put your face close to suspected leaks. Hold a piece of cardboard close to suspected leaks and then inspect the cardboard for signs of hydraulic oil. If hydraulic oil penetrates your skin, get medical help quickly.**

**Note:** Check tightness of nuts, bolts, screws and hose fittings after the first days of operation and thereafter in accordance with the maintenance schedule

**Note:** The engine oil should be replaced after the first 8 hours of operation and thereafter in accordance with the maintenance schedule in the engine manufacturer's operating and maintenance instructions

**Every 3 months**

1. Do the daily jobs
2. Check tightness of nuts, bolts, screws and hose fittings
3. Clean the air cleaner element (see engine manufacturer's handbook)

**Every 300 hours or every year**

1. Do the daily jobs and jobs every 3 months
2. Change the hydraulic oil
3. Change the hydraulic oil filter

**Scrapping and waste disposal**

Used and worn out parts must be treated and disposed of in such a way that the greatest possible part of them can be recycled and the influence on the environment kept as low as possible

**TROUBLE SHOOTING****WARNING**

**Maintenance must be done only by suitably qualified and competent persons.**

<b>Problem</b>	<b>Cause</b>	<b>Solution</b>
Engine turns over but does not start	No fuel	Top up tank
	Fuel line blocked	Clear line
	Fuel tap in position 0	Move the fuel tap to position 1
	Engine malfunction	Refer to engine manual
Engine does not turn over or is difficult to turn	By-pass valve in the ON position	Turn valve to OFF
	Engine malfunction	Refer to engine manual
	Battery uncharged	Start engine with recoil start or recharge battery
Low hydraulic oil level	Damaged hoses	Check and replace if needed
	Leaking connections	Check for tightness/leaks
	Defect hose couplings	Replace couplings
Poor tool performance	Low pressure relief valve setting	Adjust valve
	High back pressure	Check hose system for blockage
	Worn hydraulic pump	Replace pump

Problem	Cause	Solution
Frothy or creamy coloured hydraulic oil	Air or water in oil	Check for loose connections on line to pump
		Make sure that the filler cap on the tank is not loose
		Check that oil level is at the top of the sight glass
Tool runs hot	Poor siting of Power Pack causing warm air to recirculate	Resite Power Pack for free air circulation
	Blocked oil cooler	Blow cooler clean. <b>NEVER</b> use a wire brush
	Defect fan	Replace fan
	Back pressure too high	Check hose system
	Tool defect	Check and service tool
Power Pack stops suddenly	Out of fuel	Top up tank

## TECHNICAL DATA

### Dimensions

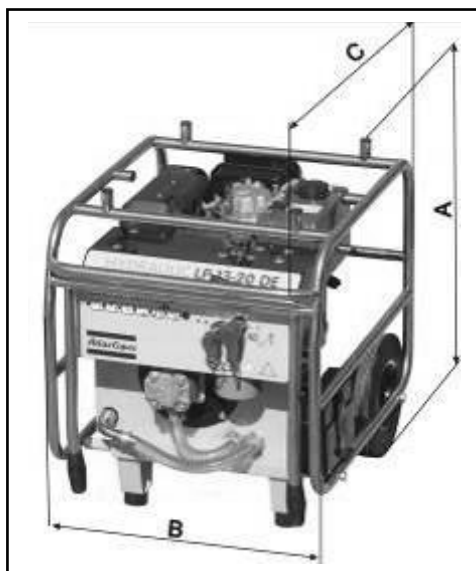

Height (A)	705 mm (27.7")
Width (B)	600 mm (23.6")
Length (C)	745 mm (29.3")
Weight with oil	116 kg (256 lbs)

### Engine type

Engine Yanmar, air cooled, 1 cylinder 4-stroke diesel engine with electric start

Performance 10 HP (7.4 kW) at 3600 rpm

Fuel Diesel

Starter Electric start and recoil hand start

### Hydraulic system

Circuit type Open centre

Pump type Gear pump, directly driven from the engine crankshaft by means of a flexible coupling

Filtration 25 $\mu$  filter in return line. Filter by-pass valve in valve block

Cooling system Thermostatically controlled air blast oil cooler

## Fluids, lubricants, capacity and specification

Item	Capacity	Fluid/lubricant
	Litres (gal,US)	
Engine (oil)		Refer to manufacturer's operating and maintenance instructions.
Fuel tank	4.7 (1.24)	Diesel, cetan value more than 45
Hydraulic fluid	7 (1.85)	Mobil EAL 224 or similar

## Flow rates

The European Hydraulic Tool Manufacturers Association (E.H.T.M.A.) has categorised hydraulic power packs and tools in terms of flow rate and working pressure.

Our LP 13-20 DE PAC is categorised by the E.H.T.M.A. as below:

Flow rate, l.p.m. (gal,US)	20 (5)
Nominal pressure, bar (psi)	120 (1800)
Max. pressure, bar (psi)	140 (2000)
E.H.T.M.A. category	C

**Note:** Atlas Copco hydraulic power packs are clearly marked with E.H.T.M.A. categories. It is important that any tool used with the Power Pack is of a compatible category. If any doubt, consult your Atlas Copco dealer.



## IMPORTANT

The torque of the engine is reduced when reducing the rpm. The Power Pack can therefore not in all cases deliver the maximum pressure at low rpm.

## Hose length

- 1 In normal ambient temperature, 0-40 °C (32-104 °F), the maximum hose length should not exceed 25 m (82 ft)
- 2 Normally, 7 m of Twin hoses are to be used for the Power Pack.

Twin hose and other accessories are shown in the spare parts list.



## WARNING

The setting of the pressure relief valve on the Power Pack can in some cases be higher than the prescribed max. pressure according to the E.H.T.M.A. category.

A too high pressure relief valve setting can harm the tool.

Readjust the pressure relief valve on the Power Pack if the technical specifications of the tool prescribe a lower pressure relief valve setting than the standard setting of the Power Pack.