

LP 18-2x20/1x40 Twin PE PAC

Power Pack



LP 18-2x20/1x40 Twin PE PAC

Safety and Operating Instructions

Atlas Copco

CONTENTS

INTRODUCTION	2
SAFETY INSTRUCTIONS	2
Introduction to safety	2
Safety symbols used	2
General safety rules	3
Protective equipment.....	3
MARKINGS	4
Identification	4
CE	4
Safety signs on the Power Pack	4
GENERAL INFORMATION.....	4
Parts identification	5
OPERATING INSTRUCTIONS	6
Preparation before starting	6
Starting the engine.....	7
Stopping the engine.....	7
Hydraulic control and connectors.....	7
Connecting/disconnecting hoses	8
How to check the hydraulic system	9
Service schedules	9
Scrapping and waste disposal	10
TROUBLE SHOOTING	11
TECHNICAL DATA.....	12
Noise declaration statement	13

INTRODUCTION

These operating and safety instructions must be read before operating the machine. Instructions for operation and basic maintenance are included. The purpose of this booklet is to give the machine user an understanding of how to safely and efficiently use and maintain the machine.

SAFETY INSTRUCTIONS

Introduction to safety

SAFETY INSTRUCTIONS	
<ul style="list-style-type: none">• Before starting, read all instructions carefully	
<ul style="list-style-type: none">• Special attention must be paid to information alongside this symbol	
<ul style="list-style-type: none">• Only use Atlas Copco genuine parts	

To reduce the risk of serious injury to yourself or others, read these safety instructions before using the Power Pack. Post these safety instructions at work locations, provide copies to employees, and make sure that everyone reads the safety instructions before using the Power Pack. Comply with all safety regulations.

These instructions have been compiled from international safety standards and form part of the operating instructions. Signs and decals that are important for your safety and the care of the Power Pack are included with each power pack. Make sure that they are legible. New decals can be ordered using the spare parts list.

Safety symbols used

The indications DANGER, WARNING and CAUTION, as used in the safety instructions, have the following meanings:



DANGER

Immediate hazard which WILL result in serious or fatal injury if the warning is not observed



WARNING

Hazard or hazardous procedure which COULD result in serious or fatal injury if the warning is not observed



CAUTION

Hazard or hazardous procedure which COULD result in injury or damaged equipment if the warning is not observed

General safety rules

- The Power Pack and accessories must only be used for their purpose
- Learn how the Power Pack is switched off in the event of an emergency
- Only qualified and trained persons may operate or maintain the Power Pack
- Keep the Power Pack in a safe place out of the reach of children, locked up
- Pay attention and look at what you are doing
- Use your common sense
- Do not use the Power Pack when you are tired or under influence of drugs, alcohol or anything else that may influence your vision, reaction or judgement
- Never leave the Power Pack turned on
- Avoid lifting a higher weight than that allowed according to your local environmental working regulations
- Regular maintenance is prerequisite for machine safety. Carefully follow the operating instructions. Replace damaged and worn components in good time. For major service to the Power Pack, contact your nearest authorized workshop. When cleaning mechanical parts with solvent, make sure to comply with current health and safety regulations and ensure sufficient ventilation
- Breathing the Power Pack's exhaust gases can harm and possibly kill you. Do not start or run the Power Pack in enclosed areas, even if the doors and windows are open. Start and run the Power Pack outdoors.

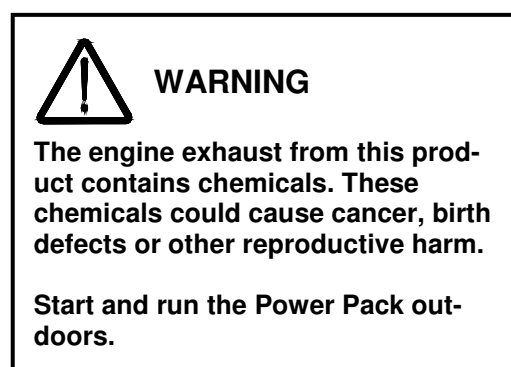

- Explosions and fire can be caused by sparks from the exhaust or the electrical system. Do not use the machine in closed areas with flammable material, vapour or dust.

Protective equipment

Always use approved personal protective equipment. Operators and other staff in the proximity areas where work is in progress must as a minimum use the following approved protective equipment:

- Hearing protection

When the Power Pack is used as a power source for breakers, cut-off saws and similar tools, use the following personal protective equipment:

- Protective helmet
- Safety glass with side protection
- Respiratory protection when appropriate
- Protective gloves
- Protective boots

MARKINGS

Identification

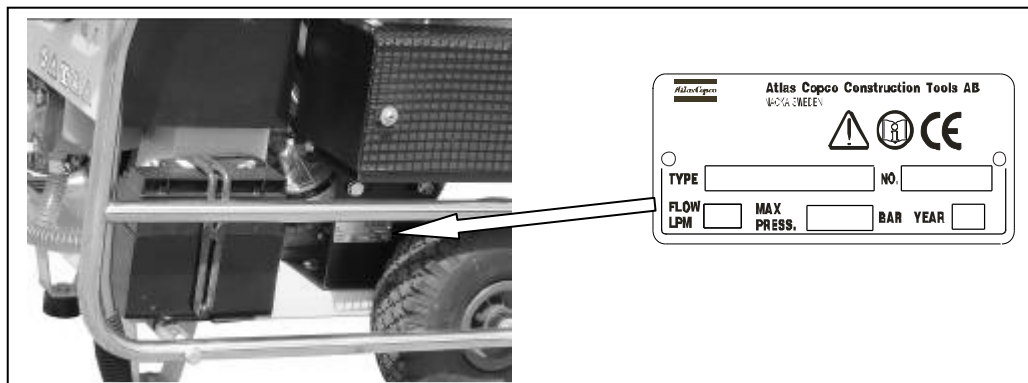

CE

The CE marking verifies that the machine is CE approved. The marking is on the ID-tag. See the “Declaration of Conformity” supplied with the Power Pack for more information.

Safety signs on the Power Pack

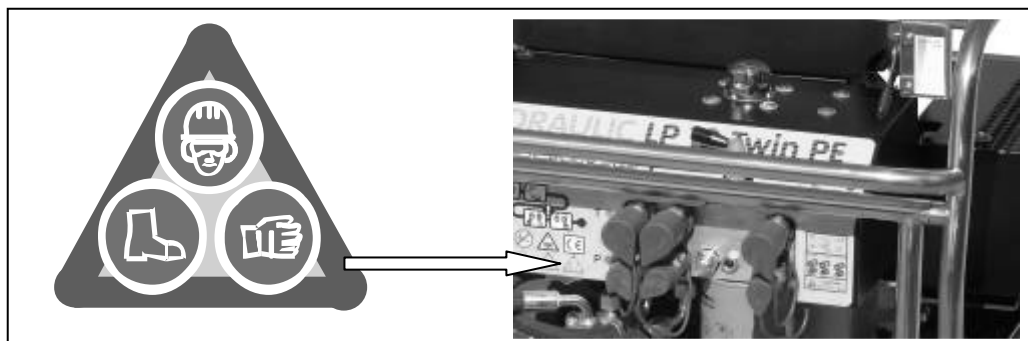

GENERAL INFORMATION

The Atlas Copco LP 18-2x20/1x40 Twin PE PAC is a hydraulic Power Pack designed for operating Atlas Copco hydraulic breakers and other tools.

The Power Pack is fitted with an 18 HP Briggs & Stratton Vanguard V-Twin, air cooled engine with hydraulic POD system. The LP 18-2x20/1x40 Twin PE PAC can provide a flow of 2x20 l.p.m. or 1x40 l.p.m.

Parts identification

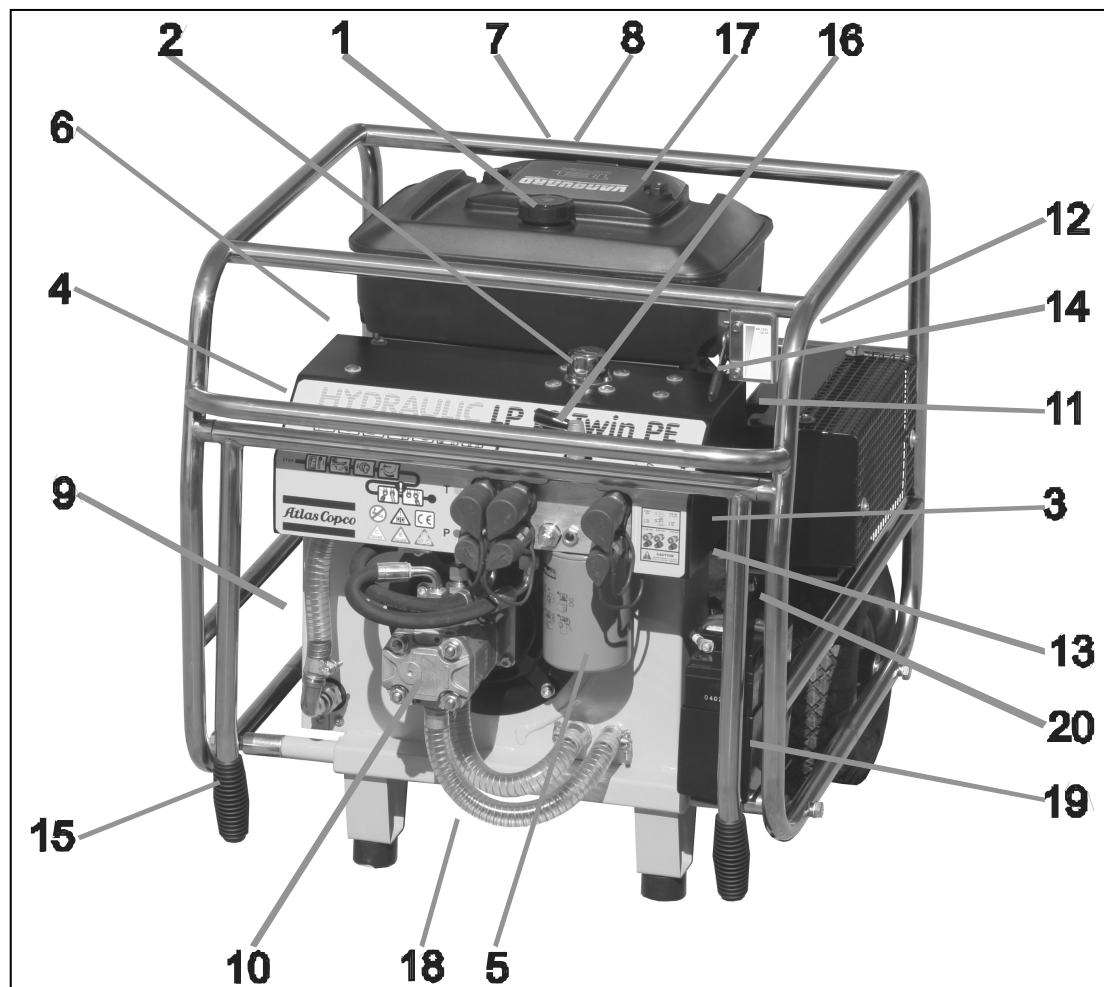

- | | | | |
|----|----------------------------------|----|-----------------------|
| 1 | Filler cap, fuel | 11 | Choke control |
| 2 | Filler cap, hydraulic oil | 12 | Recoil start |
| 3 | Sight glass, hydraulic oil level | 13 | Pressure relief valve |
| 4 | Filter condition gauge | 14 | Throttle lever |
| 5 | Hydraulic oil filter | 15 | Foldable handles |
| 6 | Engine oil, dipstick | 16 | By-pass valve |
| 7 | Ignition switch OFF and ON | 17 | Air filter |
| 8 | Fuel tap | 18 | Drain plug |
| 9 | Oil cooler | 19 | Battery |
| 10 | Hydraulic pump | 20 | Engine oil filter |

OPERATING INSTRUCTIONS

Preparation before starting

The following checks should be made each time you return to the Power Pack after leaving it for a period of time. All these checks concern the serviceability of the Power Pack. Some concern your safety.

- Remove dirt and debris especially from around the linkage and hydraulic oil cooler
- Clean all safety decals. Replace any that are missing or cannot be read
- Inspect the Power Pack and hoses generally for signs of damaged and missing parts
- Check for fluid and fuel leakages beneath the Power Pack
- Check the security of the hinged frame
- Make sure the fuel filler cap is tightly closed
- Check the hydraulic oil level and add as necessary
- Position the Power Pack in a safe position
- Ensure that the hydraulic couplings are clean and fully serviceable
- Ensure that any hydraulic tool you plan to use is compatible with the model of the Power Pack you are using. See the section **Flow rates**
- Check the engine oil level and add oil as necessary
- Ensure that you have adequate fuel for the job. Top up as necessary, taking care not to overfill



WARNING

- **Petrol and its vapours are flammable and explosive. Fire or explosion can cause severe burns or death**
- **Keep naked flames away from the Power Pack**
- **Do not smoke while refuelling the Power Pack or working with the engine**
- **Do not refuel with the engine running. Turn off the engine and let the engine cool for at least 2 minutes before refuelling**
- **Do not overfill the tank. Fill the tank approx. 30-40 mm (1-1½ inches) below the top of the neck to allow for fuel expansion**

Starting the engine

1. Turn on the fuel by turning the ON/OFF control (A) to the ON position
2. Pull the choke control (B) to closed position. If the engine is warm, or the ambient temperature high, the choke control should be set in the OPEN position
3. Turn the hydraulic by-pass valve (C) to the OFF position for take-out A, B and C
4. Turn the ignition key (D) clockwise. Let the ignition key go back to vertical position, when the engine starts



CAUTION

In order not to damage the starter, do not activate the starter for more than 15 seconds per minute. Let the starter cool off for 2 minutes before the next try.



WARNING

When starting the engine with the recoil hand start:

- Set the by-pass valve in the OFF position
- Pull the cord slowly until resistance is felt, then pull rapidly

A rapid retraction of the starting cord (kickback) will pull your hand and arm towards the engine faster than you can let go. Broken bones, fractures, bruises or sprains could be the result.

5. As the engine warms up, gradually move the choke control (B) to the OPEN position

Stopping the engine

1. Turn the hydraulic by-pass valve (C) to the OFF position for take-out A, B and C
2. Turn the ignition key (D) counter clockwise to the OFF position
3. Turn off the fuel by turning the ON/OFF control (A) to the OFF position

Hydraulic control and connectors

The by-pass valve (F) shall be in the OFF position when starting and in the ON position when using the tool.

Connectors (G) and (H) are used to connect the Power Pack to the tool as follows:

- Connector (G) Return (female)
- Connector (H) Feed (male)

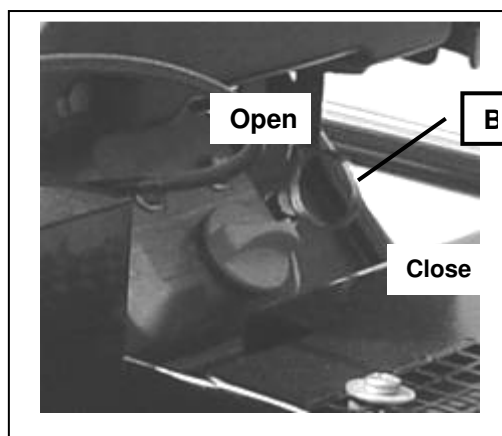
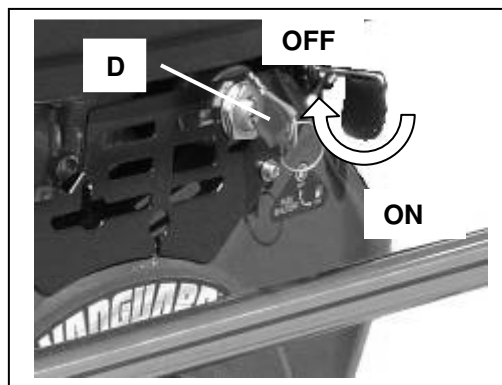



Connecting/disconnecting hoses



CAUTION

Ensure that any tool you plan to use is compatible with the model of the Power Pack you are using.

Non-compatible tools might harm both the Power Pack and the tools.

Check the section Flow rates in this instruction book and compare the flow rate with the technical specifications in the instruction book for the tool.

Function of the by-pass valve

The by-pass valve is a multiple function valve. It controls the flow to the three power take-outs (A, B and C). The four positions on the valve are:

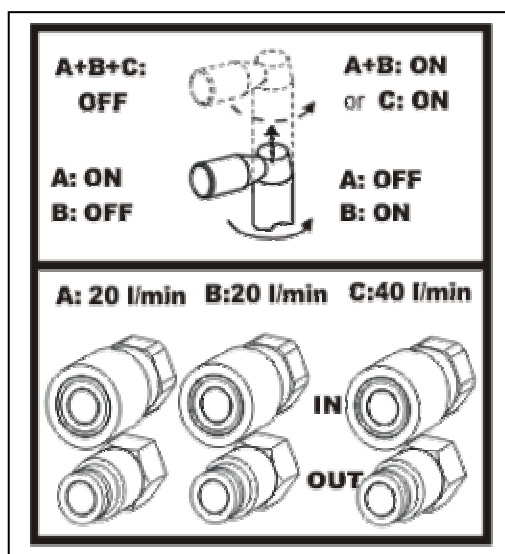

Pos.	Flow
1	A = 20 l.p.m. and B = OFF
2	A = OFF and B = 20 l.p.m.
3	A = 20 l.p.m. and B = 20 l.p.m. or C = 40 l.p.m.
4	A = OFF, B = OFF and C = OFF



CAUTION

Never connect a 20 l.p.m. tool to the C take-out. The take-out C is only for 40 l.p.m. tools.

Connecting hoses

- Prepare the Power Pack
 - Turn the by-pass valve to the OFF position for take-out A, B and C
 - Stop the engine
- Inspect the couplings
 - Ensure that the couplings are clean and serviceable
- Connect the hoses
 - Attach the return line
 - Attach the feed line
 - Rotate the collar on the female coupling to secure the coupling
- Check the hydraulic oil level
 - Start the engine and run the Power Pack to fill up the hydraulic circuit
 - Check the hydraulic oil level

Disconnecting hoses

- Prepare the Power Pack
 - Turn the by-pass valve to the OFF position
 - Stop the engine
- Remove the hoses
 - Rotate the collar on the female coupling
 - Release the return line
 - Release the feed line

Note: The couplings are unlocked by moving the collar back on the coupling

**WARNING**

Do not disconnect the hoses when the Power Pack is running or if the hydraulic oil is hot.

Hot hydraulic oil might cause serious burns.

How to check the hydraulic system

To set or check the oil flow and the pressure relief valve we recommend using the Atlas Copco test equipment or similar test equipment

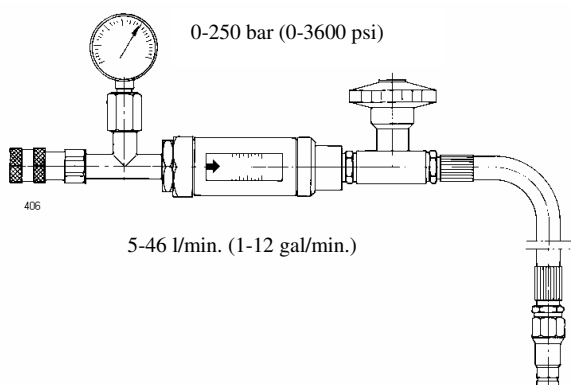

Part number 3371 8011 54

How to check

1. Stop the engine (see the section **Stopping the engine**)
2. Connect the test equipment to the Power Pack. Male (B) to the return connector and female (A) to the feed connector on take-out A. Make sure that the loading valve of the test equipment is fully open
3. Start the engine (see the section **Starting the engine**)
4. Move the by-pass valve on the Power Pack to the ON position
5. Turn the loading valve, until the gauge shows approx. 70 bar (1000 psi) and allow the Power Pack to warm up for 3-4 minutes

6. Slowly close the loading valve until the pressure gauge shows the nominal pressure according to the technical specifications
7. Check that the flow is according to the flow rate in the technical specifications

Note: The inaccuracy of the reading on the flow meter is ± 2 l.p.m. (± 0.5 gal/min)

8. Repeat point (7) with take-out B

If the performance is not in accordance with the technical specifications for the Power Pack, please see the section **TROUBLE SHOOTING**

IMPORTANT

Do not have a tool connected to take-out C while testing the flow on A or B. That might give a misreading of the flow and pressure

Service schedules

A poorly maintained Power Pack is a hazard. Doing regular maintenance and lubrication jobs as listed in these schedules will help keep the Power Pack in a safe working condition.

Apart from the daily jobs, the schedules are based on the operation hours of the Power Pack. Keep a regular check of hours in use. Do not use a Power Pack that is due for regular service. Rectify any defects found during regular maintenance before clearing the Power Pack for use.

**WARNING**

Maintenance must be done only by suitably qualified and competent persons.

Before doing any maintenance, make sure that the Power Pack is safe and correctly sited on level ground.

Daily

1. Clean the Power Pack in general
2. Check fuel lines, tank, fuel cap and fittings for cracks or leaks. Replace if necessary
3. Check for damages
4. Check hydraulic fluid level
5. Check engine oil level
6. Check hydraulic couplings
7. Check hydraulic hoses
8. Check hydraulic oil filter

IMPORTANT

When the filter gauge needle remains in the red sector (while the engine is running idle and the oil is service warm), the filter must be replaced. The old filter is removed by turning it clockwise (use a filter strap wrench if necessary). Tilting the Power Pack rearwards will minimise oil spilling.

Before mounting the new filter, it is recommended to grease the surface of the seal with oil in order to ease correct tightening of the filter.

**WARNING**

Fine jets of hydraulic oil at high pressure can penetrate the skin. Do not use your fingers to check for hydraulic oil leaks. Do not put your face close to suspected leaks. Hold a piece of cardboard close to suspected leaks and then inspect the cardboard for signs of hydraulic oil. If hydraulic oil penetrates your skin, get medical help quickly.

Every 3 months

1. Do the daily jobs
2. Check tightness of nuts, bolts, screws and hose fittings
3. Clean the air cleaner element (see engine manufacturer's handbook)

Every 300 hours or every year

1. Do the daily jobs and jobs every 3 months
2. Change the hydraulic oil
3. Change the hydraulic oil filter

Scrapping and waste disposal

Used and worn out parts must be treated and disposed of in such a way that the greatest possible part of them can be recycled and the influence on the environment kept as low as possible.

Note: Check tightness of nuts, bolts, screws and hose fittings after the first days of operation and thereafter in accordance with the maintenance schedule

Note: The engine oil should be replaced after the first 8 hours of operation and thereafter in accordance with the maintenance schedule in the engine manufacturer's operating and maintenance instructions

TROUBLE SHOOTING



WARNING

Maintenance must be done only by suitably qualified and competent persons.

Problem	Cause	Solution
Engine turns over but does not start	No fuel	Top up tank
	Fuel line blocked	Clear line
	Fuel tap in position 0	Turn tap to position 1
	Choke not tripped	Trip choke
	Engine malfunction	Refer to engine manual
Engine does not turn over or is difficult to turn	By-pass valve in the ON position	Turn valve to OFF
	Engine malfunction	Refer to engine manual
	Battery uncharged	Start engine with recoil start or recharge battery
Low hydraulic oil level	Damaged hoses	Check and replace if needed
	Leaking connections	Check for tightness/leaks
	Defect hose couplings	Replace couplings
Poor tool performance	Low pressure relief valve setting	Adjust valve
	High back pressure	Check hose system for blockage
	Worn hydraulic pump	Replace pump
	A tool connected to take-out C while take-out A or B are used – or a tool connected to take-out A or B while take-out C is used	Disconnect one of the tools. Take-out C can only be used with no tool connected to either take-out A or B
	Incorrect POD setting	Adjust to increase engine speed

Problem	Cause	Solution
Frothy or creamy coloured hydraulic oil	Air or water in oil	Check for loose connections on line to pump
		Make sure that the filler cap on the tank is not loose
		Check that oil level is at the top of the sight glass
Tool runs hot	Poor siting of Power Pack causing warm air to recirculate	Resite Power Pack for free air circulation
	Blocked oil cooler	Blow cooler clean. NEVER use a wire brush
	Defect fan	Replace fan
	Back pressure too high	Check hose system
	Tool defect	Check and service tool
Power Pack stops suddenly	Out of fuel	Top up tank

TECHNICAL DATA

Dimensions

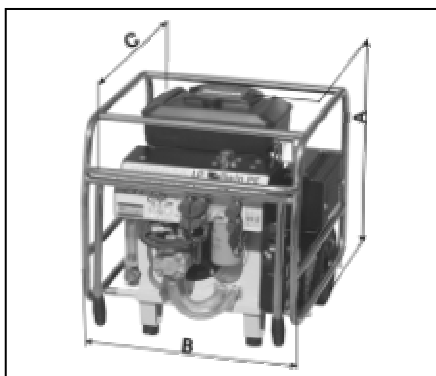

Height (A)	720 mm (28.3")
Width (B)	700 mm (27.6")
Length (C)	745 mm (29.3")
Weight with oil	110 kg (243 lbs)

Engine type

Engine	Briggs & Stratton Vanguard V-Twin, air cooled, 2 cylinder, 4 stroke with transistor ignition system
Performance	18 HP (13.2 kW) at 3600 rpm
Fuel	Petrol
Starter	Electric start and recoil hand start
Charging coil	16 A DC
Battery	12 V 17 Amp

Hydraulic system

Circuit type	Open centre
Pump type	Tandem gear pump, directly driven from the engine crankshaft by means of a flexible coupling
Filtration	25µ filter in return line. Filter by-pass valve in valve block
Cooling System	Thermostatically controlled air blast oil cooler

Fluids, lubricants, capacity and specification

Item	Capacity Litres (gal,US)	Fluid/lubricant
Engine (oil)	Refer to manufacturer's operating and maintenance instructions.	
Fuel tank	7.2 (1.9)	Unleaded petrol
Hydraulic fluid	7 (1.85)	Mobil EAL 224 or similar

Flow rates

The European Hydraulic Tool Manufacturers Association (E.H.T.M.A.) has categorised hydraulic power packs and tools in terms of flow rate and working pressure.

Our LP 18-2x20/1x40 Twin PE PAC is categorised by the E.H.T.M.A. as below:

Flow rate:	l.p.m. (gal,US)	2x20/1x40 (2x5/1x10)
Nominal pressure, bar (psi)		120 (1800)
Max pressure, bar (psi)		150 (2200)
E.H.T.M.A. category		C and E

Note: Atlas Copco hydraulic power packs are clearly marked with E.H.T.M.A. categories. It is important that any tool used with the Power Pack is of a compatible category. If any doubt, consult your Atlas Copco dealer





WARNING

The setting of the pressure relief valve on the Power Pack can in some cases be higher than the prescribed max. pressure according to the E.H.T.M.A. category. A too high pressure relief valve setting can harm the tool.

Readjust the pressure relief valve on the Power Pack if the technical specifications of the tool prescribe a lower pressure relief valve setting than the standard setting of the Power Pack.

Hose length

- 1 In normal ambient temperature, 0-40°C (32-104°F), the maximum hose length should not exceed 25 m (82 ft)
- 2 Normally, 7 m of Twin hoses are to be used for the Power Pack.

Twin hose and other accessories are shown in the spare parts list.

Noise declaration statement

Total emitted A-weighted sound power level (2000/14/EC):

Measured*	L _{WA m}	99 dB re 1 pW
Declared	L _{WA d}	101 dB re 1 pW
Guaranteed	L _{WA g}	101 dB re 1 pW
K value	K.....	1.4 dB

* Based on max. r.p.m. = 2800, pressure = 110 bar and flow = 38 l.p.m.

Sound pressure level 1 m L_{PA} (EN/ISO 11203) 88 dB

These declared values were obtained by laboratory type testing in compliance with the stated standards and are not adequate for use in risk assessment. Values measured in individual work places may be higher than the declared values. The actual exposed values and risk of harm experienced by an individual user are unique and depend upon the way the user works, the work place as well as the exposure time and the physical condition of the user.

IMPORTANT

We, Atlas Copco Construction Tools AB, cannot be held liable for the consequences of using the declared values, instead of values reflecting the actual exposure, in an individual risk assessment in a work place situation, over which we have no control.

